

• FEATURES

- Digital synchronous buck PWM controller with 175ps PWM resolution
- Digital control with programmable PID compensation
- Vin from 4.5V to 15.5V (UCD7230)
- Vout from 1% to 99% of Vin
- Programmable switching frequency, capable of up to 2MHz/Phase
- Programmable soft start and soft stop
- Supports pre-biased outputs
- 0.5% internally trimmed 800mV Reference
- Remote sensing differential amplifier
- Power supply monitoring via PMBus
- Single bias supply (3.3V VDD)
- Graphical user interface configuration
- Internal thermal sensor
- PMBus Support
 - Query Voltage, Current, Faults, etc
 - Voltage Setting and Calibration
 - Protection Threshold Adjustment
- 32-Pin QFN Package

• APPLICATIONS

- Networking Equipment
- Servers
- Storage Systems
- Telecommunications Equipment
- DC Power Distributed Systems
- Industrial / ATE

• DESCRIPTION

The UCD9111 is single phase synchronous buck digital PWM controller that supports point of load (POL) applications. The device is configured thru the use of a graphical user interface (GUI). The loop compensator is configurable with the GUI to meet dynamic converter performance allowing a single hardware design to cover a broad range of POL applications.

In addition to digital control loop, the UCD9111 is able to monitor power supply operating conditions and report the status to the host system through PMBus. The monitoring parameters are configurable through GUI. The GUI also allows the power supply designer to easily to configure the digital control loop characteristics and generate the loop gain bode plot.

The UCD7230 synchronous buck driver has been designed to work with the UCD911x controller to provide a highly integrated digital power solution. In addition to 4A output drive capability, the driver integrates current limit, short circuit protection as well as under-voltage lockout protection. The UCD7230 also has a 3.3V, 10mA linear regulator that provides the supply current for the controller.

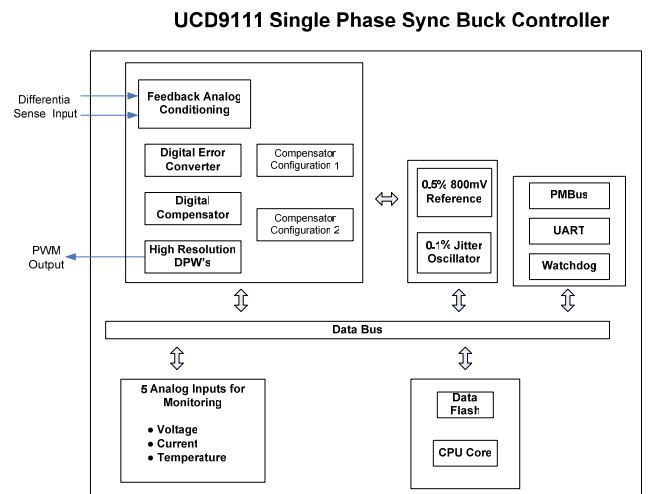
ORDERING INFORMATION

PACKAGE	TAPE AND REEL QTY	PART NUMBER
QFN	250	UCD9111RHB

Table of Contents
Features

1 Device Information	3
1.1 System Block Diagram	3
1.2 Example Dual Phase Implementation	4
1.3 Pin Assignment	5
1.4 Pin Functions	5
2 Device Ratings	7
2.1 Absolute Maximum Ratings	7
2.2 Recommended Operating Conditions	7
2.3 Electronic Discharge (ESD) Protection	7
3 Electrical Characteristics	8
4 Typical Characteristics	11
5 Function Overview	11
5.1 Reset	11
5.1.1 Power-on Reset	11
5.1.2 Brown-out Reset	11
5.1.3 Watchdog Timer	11
5.1.4 External Reset	11
5.2 Analog Inputs	12
5.2.1 Resolution	12
5.2.2 Input Impedance	12
5.3 PMBus Address	13
5.4 PID Compensator	14
5.5 Output Voltage Sensing	15
6 PMBus interface	16
6.1 PMBus Timing	16
6.2 Output Configuration Commands	16
6.2.1 Remote ON/OFF	16
6.2.2 Output Voltage Set Point	17
6.2.3 Output Voltage Calibration	17
6.2.4 Margin up/down	17
6.2.5 Output Current Measurement	17

6.2.6 Start up into Pre-Bias	18
6.2.7 Output Voltage Sequencing	18
6.2.8 Output Voltage Soft Start	19
6.2.9 Output Voltage Soft Stop	19
6.2.10 Power Good (PGOOD)	19
6.3 Protection Commands	20
6.3.1 Input Under Voltage Protection	20
6.3.2 Input Over Voltage Protection	21
6.3.3 Output Over Voltage Protection	21
6.3.4 Output Under Voltage Protection	22
6.3.5 Output Over Current Protection	22
6.3.6 Over Temperature Protection	23
6.4 Status & Fault Reporting Commands	24
6.5 Non-Volatile Storage Commands	24
6.6 Host data Storage Commands	25

7 GUI	26
--------------	-----------

8 Package Information	29
------------------------------	-----------

List of Figures

Figure 1-1 UCD9111 Block Diagram	3
Figure 1-2. UCD9111 with the UCD7230	4
Figure 1-3. UCD9111 Pin Assignment	5
Figure 3-1 PMBus Timing Diagram	10
Figure 5-1 V_{addr} to PMBus address translation	13
Figure 5-2 Output voltage sensing circuitry	15
Figure 6-1 Current Gain and Offset	18
Figure 8-1 GUI Interface for POL Configuration	27
Figure 8-2 GUI Design Tool	28
Figure 9-1 32-Pin PowerPAD™ QFN Package	29

List of Tables

Table 1-1 UCD9111 Pin Descriptions	5
Table 5-1 Device reset voltage threshold	11
Table 5-2 Analog input assignments	12
Table 5-4 Configuration of PMBus addresses	14

1 DEVICE INFORMATION

1.1 BLOCK DIAGRAM

UCD9111 Single Phase Sync Buck Controller

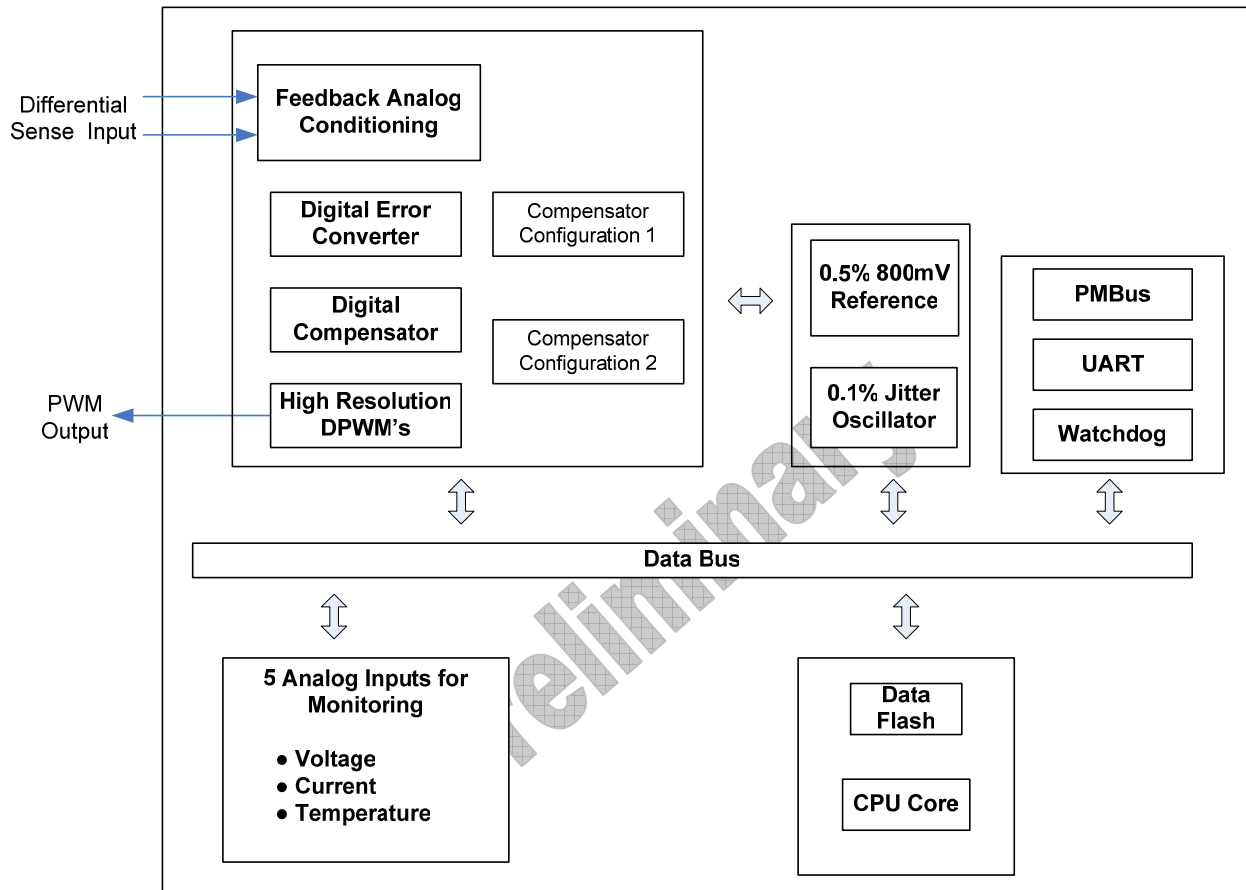

Figure 1-1. UCD9111 Block Diagram

1.2 EXAMPLE SINGLE PHASE IMPLEMENTATION WITH THE UCD7230 DRIVER

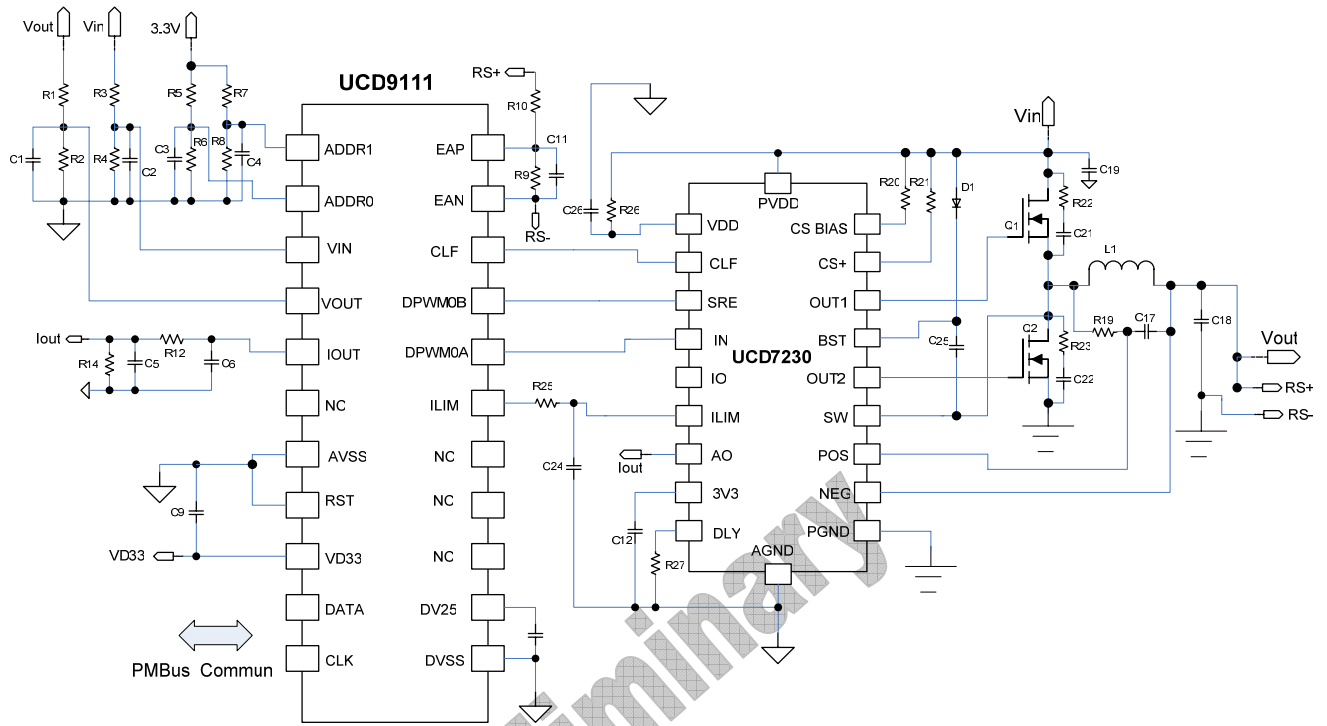

Figure 1-2. UCD9111 in a typical configuration

1.2 PIN ASSIGNMENTS

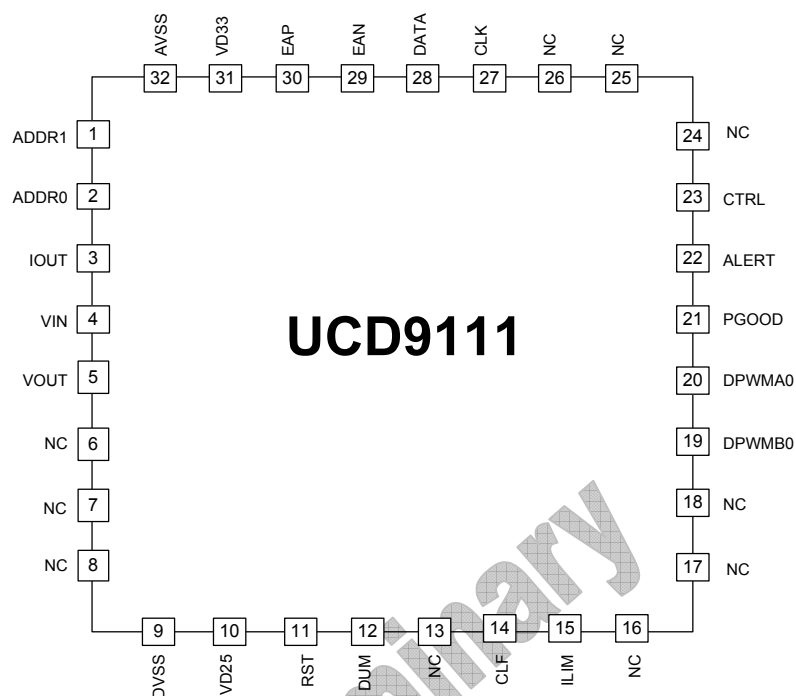

Figure 1-3. UCD9111 QFN Package Pin Assignments

1.3 PIN FUNCTIONS

Table 1.1 UCD9111 Pin Descriptions

TERMINAL PIN				DESCRIPTION
NAME	NO.	I/O	A/D	
ADDR1	1	I	A	Addr1 and Addr0 signals are analog voltage that are sampled when UCD9111 is released from reset. The voltage levels set the addresses. See the below section, PMBus Address.
ADDR0	2	I	A	
IOUT	3	I	A	Inductor current, the value is amplified in UCD7230
VIN	4	I	A	Input DC voltage sensing through resistors.
VOUT	5	I	A	Output DC voltage sensing through resistors.
NC	6	I	A	Open connection.
NC	7	-	-	Open connection.
NC	8	-	-	Open connection.
DVSS	9	-	DP	Digital ground of IC. This ground should be separate from power ground.
VD25	10	O	P	Internal 2.5V bypass pin for UCD9111. A 1 μ F ceramic cap must be connected from VD25 to DVSS.
RST	11	I	-	Pulling high resets the chip. Need a pull-down resistor and a 0.1 μ F

				decoupling capacitor.
DUM	12	-	-	Connected to analog ground AVSS.
NC	13	-	-	No connection.
CLF0	14	I	D	Over current limit flag from UCD7230.
ILIM	15	O	D	A PWM output that is used to generate an analog input to the UCD7230 current limit. The ILIM requires an RC filter consisting of 15K and 0.1uF
NC	16	-	-	Open connection
NC	17	O	D	Open connection
NC	18	O	D	Open connection.
DPWMB0	19	O	D	DPWM output to the drive UCD7230.
DPWMA0	20	O	D	DPWM output to the drive UCD7230.
PGOOD	21	O	D	Power good signal indicating power conversion status.
ALERT	22	O	D	Alert signal indicating PMBus status.
CTRL	23	I	D	ON/OFF command to turn on/off power supply.
NC	24	I	D	Open connection.
NC	25	I	D	Open connection.
NC	26	O	D	Open connection.
CLK	27	I	D	PMBus/SMBus/I ² C clock input.
DATA	28	I/O	D	PMBus/SMBus/I ² C data (bi-directional).
EAN	29	I	A	Output voltage remote sense to error amplifier negative input.
EAP	30	I	A	Output voltage remote sense to error amplifier positive input.
VD33	31	I	P	3.3V VDD bias supply.
AVSS	32	-	P	Analog ground.
PAD GND	33	-	Pad	Pad analog ground.

2 DEVICE RATINGS

2.1 ABSOLUTE MAXIMUM RATINGS

Over operating free-air temperature range (unless otherwise noted) (1)

	Range	UNIT
VD33 relative to Vss	-0.3 to 3.6	V
IO pin relative to Vss	-0.3 to 3.6	V
Operating junction temperature, T_j	-40 to 125	°C
Storage temperature, T_{sj}	-65 to 150	°C
Lead Temperature(soldering for 10 sec)	300	°C

(1) Stresses above these ratings may cause permanent damage. Exposure to absolute maximum conditions for extended periods may degrade device reliability. These are stress ratings only, and functional operation of the device at these or any other conditions beyond those specified is not implied.

2.2 RECOMMENDED OPERATING CONDITIONS

Over operating free-air temperature range (unless otherwise noted)

	Min	Typ	Max	UNIT
VD33 relative to Vss	-0.2	3.3	3.5	V
VEAP relative to VEAN	0		2.45	V
Operating free-air temperature	-40		85	°C

2.3 ELECTROSTATIC DISCHARGE (ESD) PROTECTION

PARAMETER	Min	Typ	Max	UNIT
HBM (Human Body Model)	2000			V
CDM (Charged Device Model)	500			V

3 ELECTRICAL CHARACTERISTICS

VD33 = 3.3V, TA = -40 °C to 85 °C (unless otherwise noted)

PARAMETER	CONDITIONS	MIN	TYP	MAX	UNIT
VDD Input Supply					
VD33 supply voltage		3.14	3.3	3.46	V
ICC supply current	Normal Operation	4	7	10	mA
VD25					
Output voltage range	1uF ceramic connected, without source current	2.4	2.45	2.5	V
Source current ¹	5% maximum voltage drop			-10	mA
EAP & EAN					
Input differential range		-0.2		2.5	V
Input bias current to EAP	VEAP-VEAN = 2.5V	-10		50	μA
Output source current from EAN			-10		μA
Reference resolution			1.25		mV
Bandwidth			2		MHz
PWM OUTPUT					
Duty cycle		1		99	%
Rise time (t _r)	1000pF cap load		15		ns
Fall time (t _f)	1000pF cap load		15		ns
Dead band (t _{db})	F _s = 500KHz	20		512	ns
Fault shutdown delay (t _{fd})	The count of CLF is set at zero		20		ns
Frequency (F _{sw})		30	500	2000	KHz
Frequency set point Accuracy	T _A = 25 °C			5	%
ILIM					
Frequency (F _{ii})			50		kHz
Duty cycle range		0		100	%
Fall time (t _{f_ii})	1000pF cap load		15		ns
Rise time (t _{r_ii})	1000pF cap load		15		ns
POWER GOOD					
PGood assertion delay			TBD		μs
PGood deassertion delay			TBD		μs
Low level output voltage (V _{OL})	I PGood = 5 mA			0.4	V

High level output voltage (V_{OH})	I PGOOD = -5 mA	2.8			V
PMBus AERT					
PMBus Alert assertion delay			TBD		μ s
PMBus Alert deassertion delay			TBD		μ s
Low level output voltage (V_{OL})	I alert = 5 mA			0.4	V
High level output voltage (V_{OH})	I alert = -5 mA	2.8			V
THERMAL SHUTDOWN					
Shutdown temperature	Junction temperature			TBD	$^{\circ}$ C
Hysteresis			TBD		$^{\circ}$ C
I/O CHARACTERISTICS					
High input voltage, V_{IH}	VD33=3.3V	2		3.45	V
Low input voltage, V_{IL}	VD33=3.3V			0.8	V
Input hysteresis voltage.	VD33=3.3V	0.3			V
Output Voltage High (V_{OH})	VD33=3.3V, IOH = -5mA	2.8			
Output Voltage Low (V_{OL})	VD33 = 3.3V, IOL = 5mA			0.4	
PMBus/SMBus/I2C					
FSMB PMBus/SMBus operating frequency	Slave mode, SMBC 50% duty cycle		100		kHz
FI2C I ² C operating frequency	Slave mode, SCL 50% duty cycle		400		kHz
$t_{(BUF)}$ Bus free time between start and stop		4.7			μ s
$t_{(HD:STA)}$ Hold time after (repeated) start		4.0			μ s
$t_{(SU:STA)}$ Repeated start setup time		4.7			μ s
$t_{(SU:STO)}$ Stop setup time		4.0			μ s
$t_{(HD:DAT)}$ Data hold time	Receive Mode	0			ns
	Transmit Mode	300			ns
$t_{(SU:DAT)}$ Data setup time		250			ns
$t_{(TIMEOUT)}$ Error signal/detect ⁽¹⁾		25		35	ms
$t_{(LOW)}$ Clock low period		4.7			μ s
$t_{(HIGH)}$ Clock high period ⁽²⁾		4.0		50	μ s

$t_{(LOW:SEXT)}$ Cumulative clock low slave extend time ⁽³⁾				25	ms
$t_{(LOW:MEXT)}$ Cumulative clock low master extend time ⁽⁴⁾				10	ms
t_f Clock/data fall time ⁽⁵⁾				300	ns
t_r Clock/data rise time ⁽⁶⁾				1000	ns

- (1) The UCD9111 times out when any clock low exceeds $t_{(TIMEOUT)}$.
- (2) $t_{(HIGH), Max}$, is the minimum bus idle time. $SMBC = SMBD = 1$ for $t > 50$ ms causes reset of any transaction involving UCD9110 that is in progress. This specification is valid when the NC_SMB control bit remains in the default cleared state ($CLK[0]=0$).
- (3) $t_{(LOW:SEXT)}$ is the cumulative time a slave device is allowed to extend the clock cycles in one message from initial start to the stop.
- (4) $t_{(LOW:MEXT)}$ is the cumulative time a master device is allowed to extend the clock cycles in one message from initial start to the stop.
- (5) Fall time $t_f = 0.9VDD$ to $(VILMAX - 0.15)$
- (6) Rise time $t_r = VILMAX - 0.15$ to $(VIHMIN + 0.15)$

Figure 3-1. PMBus/SMBus/I2C Timing Diagram

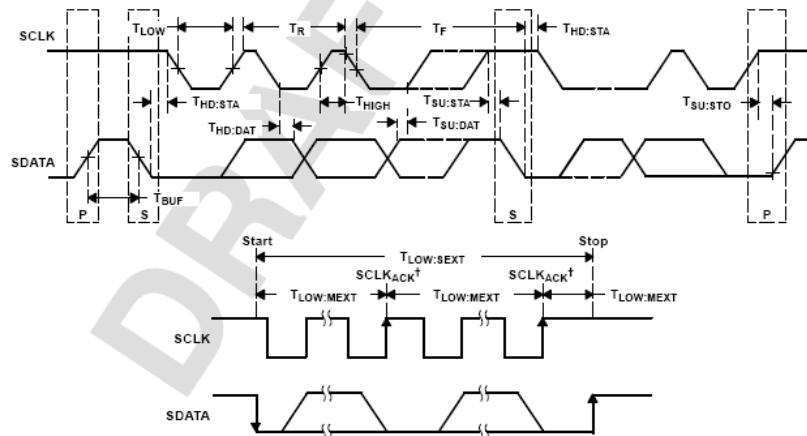

A. SCLKACK is the acknowledge-related clock pulse generated by the master.

4 TYPICAL CHARACTERISTICS

To be included in later revision of the data sheet

5 FUNCTION OVERVIEW

5.1 RESET

5.1.1 Power-on Reset

The UCD9111 has an integrated reset block which monitors the supply voltage. At power-up, the POR detects the VD33 rise. When VD33 is greater than a predetermined reference point, VRST, a reset pulse is generated and a startup delay sequence is initiated. At the end of the delay sequence, the system reset signal is deasserted and the device begins normal operation. (See Table 5-1)

In applications with long VD33 rise times, the external reset (RST) should be used to ensure startup occurs when the supply voltage is greater than the minimum operating voltage. At the normal operating condition, this RST pin must be connected to a parallel combination of a 10kΩ resistor and 0.1μF capacitor to AVSS.

5.1.2 Brown-out Reset

The UCD9111 also has an integrated Brown-out Reset circuit that is used to generate a reset when the supply voltage falls below a fixed trip reference voltage. The device is held in reset until the supply voltage rises above the minimum voltage threshold, at which time a new reset pulse is generated and the POR circuit restarts the device. (See Table 5-1)

5.1.3 Watchdog Timer

Built-in Watchdog provide protection from unpredicted operation.

5.1.4 External Reset

The device can be forced into the reset state by an external circuit connected to the Pin RST. A logic high voltage on this pin generates a reset signal. To avoid an erroneous trigger caused by the noise, a pull down resistor and a decoupling cap is necessary.

Table 5-1 Device reset voltage threshold

VD33= 3.3V, TA= -40°C to 85°C (unless otherwise noted)

Parameter	Test Conditions	Min	Typ	Max	Unit
Power-on reset, VRST		2.4	2.5	2.8	V
Brown-out threshold			2.2		V
Hysteresis			0.2		V

5.2 ANALOG INPUTS

The UCD9111 monitors 5 analog signals to determine supply operation. Table 5-2 below shows the analog input pin assignments..

Table 5-2. Analog Input assignment

Pin. No	Pin Name	Function Description
1	ADDR1	Address 1 voltage conversion
2	ADDR0	Address 0 voltage conversion
3	IOUT_0	Output current conversion
4	VIN	POL input voltage conversion
5	VOUT	POL output voltage conversion
Internal	-	Temperature sensing voltage conversion

The UCD9111 takes the proper action based on the information acquired from these analog inputs, for example turning on the DC output or sending alarm signal to the host system if the output is under voltage. The device temperature is monitored using an internal temperature sensor. The data can be reported to the host after the UCD9111 receives the commands via PMBus. The PMBus commands will be addressed in the section titled PMBus Interface.

5.2.1 Resolution

The external analog inputs have 3.22mV resolution based on a 3.3V VD33 input. The maximum input voltage at the analog input should not exceed 3.0V for proper measurement.

In some applications, a voltage divider is used to reduce the voltage level applied to the analog input. The division ratio changes the conversion resolution. .

5.2.2 Input Impedance

The input impedance is typically a 250Ω series input and a 30pF capacitor to ground. The inputs are sampled and require 60ns of settling time. It is desirable to have a 0.1uF input capacitor at each analog input pin.

5.3 PMBus ADDRESS

The Digital POL system has the ability to be configured with different PMBus addresses. To configure different addresses, a voltage will be applied to the pins ADDR1 and ADDR0 on the UCD9111.

The following table shows what PMBus addresses are indicated by the applied voltage.

Figure 5-1. V_{addr} to PMBus address translation

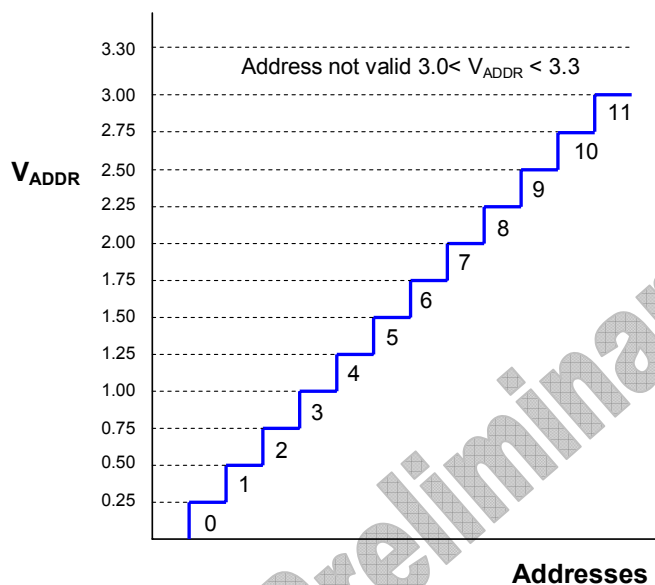

Note that the nominal value for each voltage step (and each PMBus address) is in the center of each band.

The address can be represented by the formula:

$$\text{PMBus_Addr} = \text{ADDR0} * 12 + \text{ADDR1}$$

Table 5-4 lists the examples of the PMBus address for given the voltage level on the pin1 and Pin2.

Table 5-3. The configuration of PMBus addresses

PMB_Addr0	PMB_Addr1	PBM Address	PMB_Addr0	PMB_Addr 1	PBM Address
<0.25	<0.25	0x00	0.25-0.50	<0.25	0x0C
	0.25-0.5	0x01		0.25-0.5	0x0D
	0.5-0.75	0x02		0.5-0.75	0x0E
	0.75-1.0	0x03		0.75-1.0	0x0F
	1.0-1.25	0x04		1.0-1.25	0x10
	1.25-1.50	0x05		1.25-1.50	0x11
	1.50-1.75	0x06		1.50-1.75	0x12
	1.75-2.0	0x07		1.75-2.0	0x13
	2.0-2.25	0x08		2.0-2.25	0x14
	2.25-2.50	0x09		2.25-2.50	0x15
	2.50-2.75	0x0A		2.50-2.75	0x16
	2.75-3.0	0x0B		2.75-3.0	0x17

The other address can be figured out by using the above formula. If the voltage placed on the address pins is over 3.0V or below zero, the value is not valid.

5.4 PID COMPENSATOR

The PID compensator allows the output voltage to be regulated at the set point reference level with zero steady state error and at the same time, maintain good dynamic performance. The high DC gain of the control loop maintains the zero steady state error. This is realized by an integrator in the PID compensator. However, the dynamic response may not be ideal if only an integrator exists in the control loop for different applications. To further improve step response and stability, the PID compensator should be designed with properly placed pole and zeros in order to achieve desired bandwidth and optimum phase margin, and gain margin.

The synchronous buck topology is commonly used for non-isolated DC/DC converters. The placement of the pole and zeros is determined by the output filter inductor, capacitor and the ESR parasitic. In the traditional power supply design, an operational error amplifier and external compensation components are used to implement the pole and zeros. Using the UCD9111, the output voltage is properly scaled and fed to the UCD9111 error converter. The ADC output is then fed to the UCD9111's on chip PID compensator. The compensator is configured using the graphical user interface (during development) and the configuration is stored into the UCD9111's flash memory.

5.5 OUTPUT VOLTAGE SENSING

Figure 5-2. Output voltage sensing circuitry

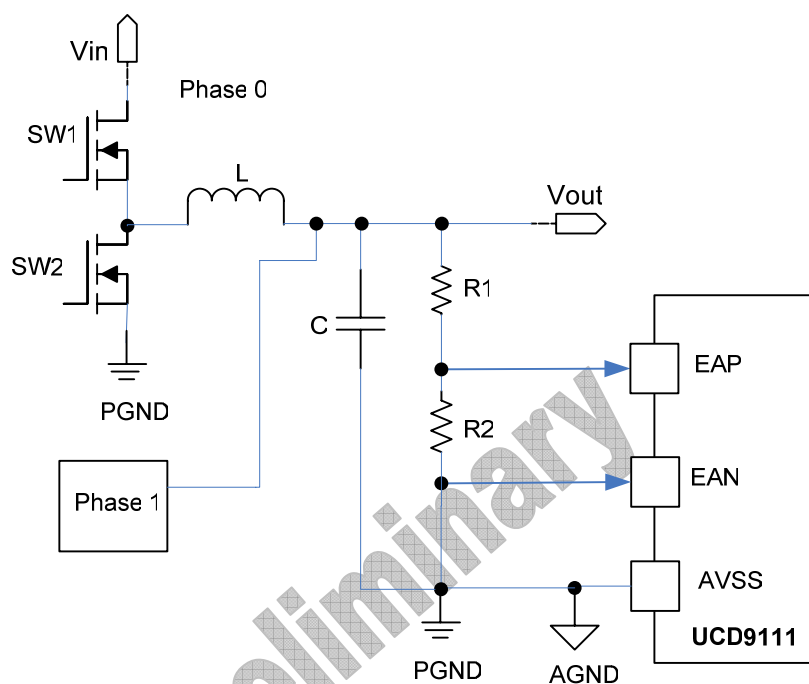

Figure 5-2 shows the voltage sensing circuitry in UCD9111. It is part of feedback loop. Two dedicated pins, EAP and EAN, are employed to sense the output voltage through differential mode. The differential sensing can effectively reduce the noise induced by the switching devices. To get a good regulation, EAP and EAN can use remote sensing to minimize the load drop. **The maximum voltage for VEAP-VEAN should be less than 2.45V. If output voltage is higher than 2.45V, a voltage divider should be used to decrease the input voltage level below 2.45V.**

6 PMBus INTERFACE

PMBus is an industry standard specification for power management. The UCD9111 supports all of the PMBus data commands that are relevant to this application. Most of the functionality in the DPOL application for the UCD9111 uses PMBus commands to support each of the functions. For each PMBus command supported in this specification, all SMBus transaction types associated with that command are also supported. This enables the user to write and read the support parameters through the PMBus commands, and SMBus transactions.

The firmware for the UCD9111 is PMBus compliant, in accordance with the "Compliance" section of the PMBus specification. The firmware is also compliant with the SMBus 1.1 specification, including support for the SMBus ALERT function.

6.1 PMBus TIMING

The timing characteristics and timing diagram for the communications interface that supports I²C, SMBus and PMBus is shown at Figure 3 in the section electrical characteristics.

6.2 OUTPUT CONFIGURATION COMMANDS

6.2.1 Remote ON/OFF

Remote on/off is supported by the software in the UCD9111 controller. This behavior is configurable and is supported by a combination of the PMBus commands below and the PMB_CTL signal which is connected to Pin 23.

The PMBus commands that support this functionality are:

ON_OFF_CONFIG

OPERATION

The ON_OFF_CONFIG command is used to configure the policy by which the unit is turned on and off, and the OPERATION command is used to turn the unit on and off according to this policy.

Power supply is turned on when PMB_CTL pin is pulled high; it is turned off when the pin is pulled down.

6.2.1 Output Voltage Set Point

The PMBus commands that support this functionality are:

VOUT_MODE

VOUT_COMMAND

VOUT_MAX

VOLTAGE_SCALE_LOOP

VOLTAGE_SCALE_MONITOR

VOUT_MODE and VOUT_COMMAND set the new output voltage mode and the VOUT_MAX command sets the maximum output voltage. VOUT_MODE is used for commanding and reading output voltage, and it consists of a three-bit mode and a five-bit parameter representing the exponent used in output voltage Read/Write. The voltage set by VOUT_COMMAND is more than VOUT_MAX, the command is ignored.

The VOLTAGE_SCALE_LOOP and VOLTAGE_SCALE_MONITOR commands are used to scaling the output voltage.

6.2.3 Output Voltage Calibration

The UCD9111 supports V_{out} output calibration. Output calibration is supported dynamically and can be changed with the supply is operational. The PMBus command that supports this functionality is:

VOUT_CAL

The VOUT_CAL command supports output voltage calibration by providing a fixed offset voltage to the output voltage command values.

6.2.4 Margin up/down

The UCD9111 supports margin up/down linearly through a programmable rate. The PMBus commands to support this functionality are:

VOUT_MARGIN_HIGH

VOUT_MARGIN_LOW

VOUT_TRANSITION_RATE

The VOUT_MARGIN_HIGH command is used to provide the unit with the voltage to which the output is to be changed when the operation is set to “margin high”. The VOUT_MARGIN_LOW command is used to provide the unit with the voltage to which the output is to be changed when the operation is set to “margin low”.

When margining up or down, the rate at which the voltage margining increases or decreases will be specified by the VOUT_TRANSITION_RATE command.

6.2.5 Output Current Measurement

There are two commands in UCD9111 to measure output current. The output current is measured by sensing the voltage drop across the DCR of each output inductor. This current is represented as the IOUT value. The PMBus commands that support this functionality are:

IOUT_SCALE

IOUT_CAL_OFFSET

The UCD9111 has two manufacturer specific commands to report the current. The IOUT_CAL_OFFSET command support output current calibration by nullifying any offsets in the current sensing circuits. The IOUT_SCALE command is used to set the ratio of the voltage at the current sense pins to the sensed current.

This can be graphically depicted as shown below.

Figure 6-1. Current Gain and Offset

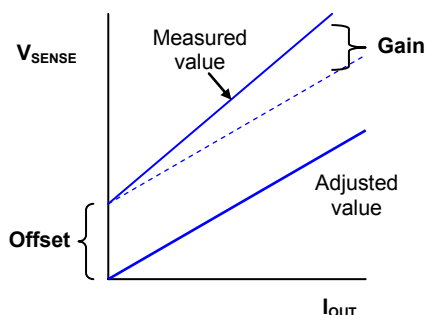

6.2.6 Start up into Pre-Bias

The UCD9111 supports starting the power supply when there is an existing output voltage when the system starts. The system will start up with an output voltage higher than the output voltage set point.

The duty cycle is calculated by dividing V_{out} by V_{in} (duty cycle = V_{out} / V_{in}). The time constant for this operation is 50 ms and regulation will be achieved by this time.

When the PMBus CONTROL line is asserted, the UCD9111 looks at the output voltage to determine if a prebias is present. The algorithm for this is as follows:

If $V_{out} < 300$ mV, then the startup is done assuming no pre-bias. Start up proceeds normally through delay and soft start states.

If $V_{out} > 3.65$ V, then the device does not attempt startup

If $V_{out} >$ output voltage set point, then disable Overvoltage Protection (OVP), calculate the duty cycle (V_{out} / V_{in}), bypass the soft start state and commence switching. When $V_{out} < V_{out_high}$ limit, re-enabled OVP. The response time from this action will be less than 10 ms.

If $V_{out} <$ output voltage set point, then turn off V_{out} low protection, calculate the duty cycle, bypass the soft start state and commence switching. When $V_{out} > V_{out_low}$, then re-enable V_{out} low protection.

There are no PMBus commands associated with this functionality.

6.2.7 Output Voltage Sequencing

The UCD9111 supports output voltage sequencing. Output voltage sequencing is started based on receiving an indication from the PMB CONTROL (PMB_CTL) signal from the system host.

The PMBus commands that support this functionality are:

TON_DELAY

TOFF_DELAY

TON_DELAY is used to specify the delay from when the PMBus CONTROL line is asserted to when the output voltage starts to rise. TOFF_DELAY is used to specify the delay from when the PMBus CONTROL line is deasserted to when the output voltage starts to fall.

6.2.8 Output Voltage Soft Start

Soft start timing starts when the PMB_CTL line is asserted (voltage rise). The system configures the delay from the assertion of the PMB_CTL signal to when the output voltage entered the regulation band. The system also configures the maximum time this process can take, without causing an undervoltage fault, and what action to take for an error.

The PMBus commands that support this functionality are:

TON_RISE
TON_MAX_FAULT_LIMIT
TON_MAX_FAULT_RESPONSE

When the voltage is rising, the TON_RISE command specifies the time from when output voltage tracking starts, to when the output voltage enters the regulation band. The TON_MAX_FAULT_LIMIT command specifies the maximum amount of time that this process can take, before an undervoltage fault will occur. The TON_MAX_FAULT_RESPONSE command specifies the action to be taken if the power supply does not reach the regulation band before the maximum time specified by TON_RISE has elapsed.

6.2.9 Output Voltage Soft Stop

Soft stop timing starts when the PMB_CTL line is deasserted (voltage fall).

TOFF_FALL
TOFF_MAX_FAULT_LIMIT
TOFF_MAX_FAULT_RESPONSE

The TOFF_FALL command specifies the time from when the voltage starts to fall to when it is off. The TOFF_MAX_FAULT_LIMIT command specifies the maximum amount of time that this process can take, before an overvoltage fault will occur. The TOFF_MAX_FAULT_RESPONSE command specifies the action to be taken if the power supply does not reach 0V by the maximum time specified in TOFF FALL has elapsed.

In the event that the voltage fails to rise or fall according to the criteria above, the STATUS_VOUT command will reflect the failure to meet the configured output voltage tracking.

6.2.10 Power Good (PGOOD)

The UCD9111 supports providing indication of power good to the host. The UCD9111 will monitor output voltage and will either assert or deassert the power good signal based on this voltage. The UCD9111 uses the PGOOD (Pin 21) as the power good signal and the polarity of this signal can be configured as active high or active low through PMBus. This signal drives an open collector GPIO pin on the host system.

Power good is asserted when the system is operational and is delivering the configured output voltage. Power good will be deasserted when any condition (fault or otherwise) causes the system to ramp down output voltage. The system will assert (or deassert) this signal within 1ms of the event that causes the transition.

The PMBus commands that support this functionality are:

POWER_GOOD_ON

POWER_GOOD_OFF

MFR_SPECIFIC_00

The POWER_GOOD_ON command is used to specify the voltage at which the Power Good signal should be asserted. The POWER_GOOD_OFF command is used to specify the voltage at which the Power Good signal should be deasserted. The MFR_SPECIFIC_00 command configures the polarity of the Power Good signal. A value of 0 in the least significant byte in this command means that the power good signal should be configured to be active low. A value of 1 in the least significant byte in this command means that the power good signal should be configured to be active high.

6.3 PROTECTION COMMANDS

UCD9111 provides lots of feature to monitor input voltage, output voltage, output current, and temperature. The threshold can be programmable through PMBus, and the status and the faults are sent to the host computer if requested.

6.3.1 Input Under Voltage Protection(VIN_UVP)

Input voltage is sensed on ADC_VIN (Pin4) of UCD9111, and the data is processed based on the threshold programmed through PMBus. The PMBus commands that will support this functionality are:

VIN_UV_WARN_LIMIT

VIN_UV_FAULT_LIMIT

VIN_UV_FAULT_RESPONSE

VIN_ON

VIN_OFF

When the input voltage starts to rise towards the regulation band, the VIN_ON command sets the voltage at which power conversion starts. When the voltage is in the regulation band, the system then observes the input voltage for both input under and over voltage warnings and faults. If the voltage falls below the value set by the VIN_OFF command, then power conversion will stop.

If the voltage falls below the value set through the VIN_UV_WARN_LIMIT command, then an under voltage warning occurs.

If the voltage continues to fall and falls below the value set through the VIN_UV_FAULT_LIMIT command, then an under voltage fault occurs. The action taken in this event is specified by the VIN_UV_FAULT_RESPONSE command.

When an under-voltage fault occurs, the VIN_UV_FAULT_RESPONSE register instructs the system how to react. There are two response bits that instruct the system what to do in the event of these failures. Input Under-voltage Fault Response Actions

6.3.2 Input Over Voltage Protection (VIN_OVP)

The UCD9111 supports warnings and faults for input over voltage protection. The latency from when the voltage goes out of range to when power is ramped down is 20ms.

The PMBus commands that support this functionality are:

VIN_OV_WARN_LIMIT
VIN_OV_FAULT_LIMIT
VIN_OV_FAULT_RESPONSE

For input over voltage *warnings*, the VIN_OV_WARN_LIMIT command is used to set the input voltage at which an over voltage warning occurs.

6.3.3 Output Over Voltage Protection (VO_OVP)

UCD9111 monitors output voltage by the VOUT (Pin5). In order to compensate for possible transient cases, when the first over-voltage reading happens, the firmware will monitor the output voltage more closely. If a second over-voltage reading happens within 100 μ s, the firmware will flag this as an over-voltage event and not just as a transient condition.

When an over-voltage fault event occurs, the firmware will send out a short PWM pulse and toggle the SRE signal to latch the sync FET on. This will make sure that the driver will try to pull down the over voltage actively through the sync FET.

The UCD9111 offers programmable output over voltage protection. The firmware can be configured to monitor (and act upon) OVP faults and warnings independently. If this condition occurs, the UCD9111 will take the action configured through the PMBus RESPONSE commands shown below.

The PMBus commands that support this functionality are:

VOUT_OV_WARN_LIMIT
VOUT_OV_FAULT_LIMIT
VOUT_OV_FAULT_RESPONSE

For output under voltage *warnings*, the VOUT_OV_WARN_LIMIT command sets the voltage at which an output under voltage warning will occur.

For output under voltage *faults*, the VOUT_UV_FAULT_LIMIT command sets the voltage at which an output under voltage fault will occur. In this event, the VOUT_UV_FAULT_RESPONSE command specifies the action to be taken.

When an OVP fault occurs, the Vout_OV_FAULT_RESPONSE register instructs the system how to react. There are two response bits that instruct the system what to do in the event of these failures.

6.3.4 Output Under Voltage Protection (VO_UVP)

When a fault condition is detected, the PMBus ALERT signal is asserted to the host controller to announce this event. The latency between the under voltage fault event and the PMBus ALERT to the host is 1 ms. After this event has occurred, the system reacts according to the configuration according to the RESPONSE commands below. The latency between the under voltage fault event happening and the UCD9111 taking the configured action is 10 ms.

The output under voltage warning does not raise the PMBus ALERT signal. The latency between when output under voltage warning threshold being crossed and the UCD9111 taking the configured action is 10 ms.

The PMBus commands that support this functionality are:

VOUT_UV_WARN_LIMIT

VOUT_UV_FAULT_LIMIT

VOUT_UV_FAULT_RESPONSE

For output under voltage *warnings*, the VOUT_UV_WARN_LIMIT command specifies the value of the output voltage that will cause an under voltage warning.

For output under voltage *faults*, the VOUT_UV_FAULT_LIMIT command specifies the value of the output voltage that will cause an under voltage fault. The VOUT_UV_FAULT_RESPONSE command will specify the action to be taken should this event occur.

When an output under voltage fault occurs, the VOUT_UV_FAULT_RESPONSE register instructs the system how to react. There are two response bits that instruct the system what to do in the event of these failures.

6.3.5 Output Over Current Protection (IO_OCP)

The UCD9111 cooperated with the UCD7230 drive monitors the output current and provides output current protection. Current is sensed either by the top FET's RDSON or by DCR of the output inductor. There are two different sensing methods and two different protections.

First, by sensing the current of top MOSFET, the cycle-by-cycle current is obtained on UCD7230. The peak current is compared to the peak current threshold set by external resistors. If the peak current of top FET is higher than the set point, the gate drive pulse is cut off, and the top FET is immediately turned off. In the event the output is short and the current increases extremely fast, this pulse-by-pulse protection can take actions immediately to avoid the damage of the power converter. When over current happens, the output of CLF is set and kept high until the next switching cycle. The UCD9111 counts the number of CLF low to high transitions. If over current continues for multiple switching cycles greater than the limit set in the UCD9111, the decision will be made by UCD9111 to shut off the DPWM outputs. The converter is going to enter hiccup mode or latched-off mode.

Second, the output current is also obtained by measuring the voltage across the DCR of each output inductor. By properly selecting RC network that is connected in parallel with the output inductor, the output inductor current is sensed and fed to the UCD7230. The UCD9111 provides current limit (I_{LIM}) threshold to the UCD7230 through a filtered PWM output. The sensed voltage across the DCR of each output inductor is compared to I_{LIM} using a high speed comparator in the UCD7230. If the $I_{CS} > I_{LIM}$, the CLF is set. The UCD9111 counts the number of CLF high to low transitions. The converter enters hiccup or latched-off mode after the number of CLF pulses is more than the limit set in the UCD9111. The current limit threshold I_{LIM} and the number of CLF pulses are programmable through PMBus.

The PMBus commands that support this functionality are:

IOUT_OC_WARN_LIMIT
IOUT_OC_FAULT_LIMIT
IOUT_OC_FAULT_RESPONSE
MFR_SPECIFIC_01

For over current warnings, the IOUT_OC_WARN_LIMIT command specifies the current at which the over current warning occurs.

For over current faults, the IOUT_OC_FAULT_LIMIT command specifies the current at which the over current fault occurs. When this event occurs, the IOUT_OC_FAULT_RESPONSE command specifies the action to be taken by the system.

The number of current limit flags to accept before taking action can be configured by using the MFR_SPECIFIC_01 command. The 16b data value from this command will represent the number of CLF events.

The inductor current of phase0 and phase1 are amplified in the UCD7230. Then, the current of each phase is input to UCD9111 on the IOUT_0 and IOUT_1. The software will monitor the output current and send warning signal if the current is over limit.

6.3.6 Over Temperature Protection (OTP)

The UCD9111 supports over temperature protection warnings and faults. There is a temperature sensor on the UCD9111 that is used for sensing over temperature events. The temperature sensor is calibrated according to a calculation based on current output and the power scale using a manufacturer specific command. The latency between over temperature events and system reaction time is 20ms.

The PMBus commands to support this functionality are:

OT_WARN_LIMIT
OT_FAULT_LIMIT
OT_FAULT_RESPONSE
MFR_SPECIFIC_02

For over temperature warnings, the OT_WARN_LIMIT command specifies the temperature at which the power supply will indicate an over temperature warning alarm.

For over temperature faults, the OT_FAULT_LIMIT command specifies the temperature at which the power supply will indicate a fault. The OT_FAULT_RESPONSE command specifies the action to be taken in the event of a temperature fault condition in the power supply.

The MFR_SPECIFIC_02 command will be used to calibrate the temperature reported by the temperature sensor on the UCD9111.

When an over-temperature fault occurs, the OT_FAULT_RESPONSE register instructs the system how to react. There are two response bits that instruct the system what to do in the event of these failures.

6.4 STATUS & FAULT REPORTING COMMANDS

The UCD9111 controller supports status and fault reporting, for maintenance of an operating supply. The PMBus commands are listed below:

STATUS_BYTE

STATUS_WORD

STATUS_VOUT

STATUS_IOUT

STATUS_INPUT

STATUS_TEMPERATURE

STATUS_CML

CLEAR_FAULTS

STATUS_BYTE command returns one byte of information with a summary of the most critical faults.

STATUS_WORD command returns two bytes of information with a summary of the unit fault condition.

STATUS_VOUT command returns one byte information of output voltage

STATUS_IOUT command returns one byte information of output current

STATUS_INPUT command returns one byte information of input voltage

STATUS_TEMPERARUE command returns one byte information of temperature

CLEAR_FAULT command clears any set faults

6.5 NON-VOLATILE STORAGE COMMANDS

The UCD9111 supports storing configuration valued to it's non-volatile memory. The latency for this operation is 1 second. The PMBus commands that support this functionality are:

STORE_DEFAULT_ALL

RESTORE_DEFAULT_ALL

STORE_DEFAULT_CODE

RESTORE_DEFAULT_CODE
STORE_USER_ALL
RESTORE_USER_ALL
STORE_USER_CODE
RESTORE_USER_CODE

The STORE_DEFAULT_ALL command stores all default values in the system to non-volatile memory. The RESTORE_DEFAULT_ALL command will set all operational values to the values stored in non-volatile memory.

The STORE_DEFAULT_CODE command will store the given value for the given command to non-volatile memory. The RESTORE_DEFAULT_CODE restore the given value for the given command to operational memory from non-volatile memory.

The STORE_USER_ALL command stores all user values in the system to non-volatile memory. The RESTORE_USER_ALL command will restore all user values from non-volatile memory to operational memory.

The STORE_USER_CODE command will store the given value for the given user command to non-volatile memory. The RESTORE_USER_CODE will restore the given value for the given command from non-volatile memory to operational memory.

6.5 HOST DATA STORAGE COMMANDS

The PMBus commands to support this functionality are:

MFR_ID
MFR_MODEL
MFR_REVISION
MFR_DATE
MFR_SERIAL

The MFR_ID, MFR_MODEL, MFR_REVISION, MFR_DATE and MFR_SERIAL commands will be used by the firmware to store that appropriate data from the release of the UCD9111 and driver, as well as firmware for the application.

8 GUI

UCD9111 provides GUI (Graphic User Interface) for the user to configure POL operating condition. The functionality of GUI supporting UCD9111 is based on the PMBus specifications compliance. The key functions of GUI are listed below:

- PID coefficients programming
- POL ON/OFF
- Vout set point
- Converter switching frequency set
- Output voltage soft start and soft stop
- Read output voltage
- Read output current
- Read input voltage
- Read temperature
- Fault threshold configuration
- Manufacturing information storage

More information is provided on the GUI User's Manual. Figure 6 is the front picture of GUI shown before users.

Preliminary

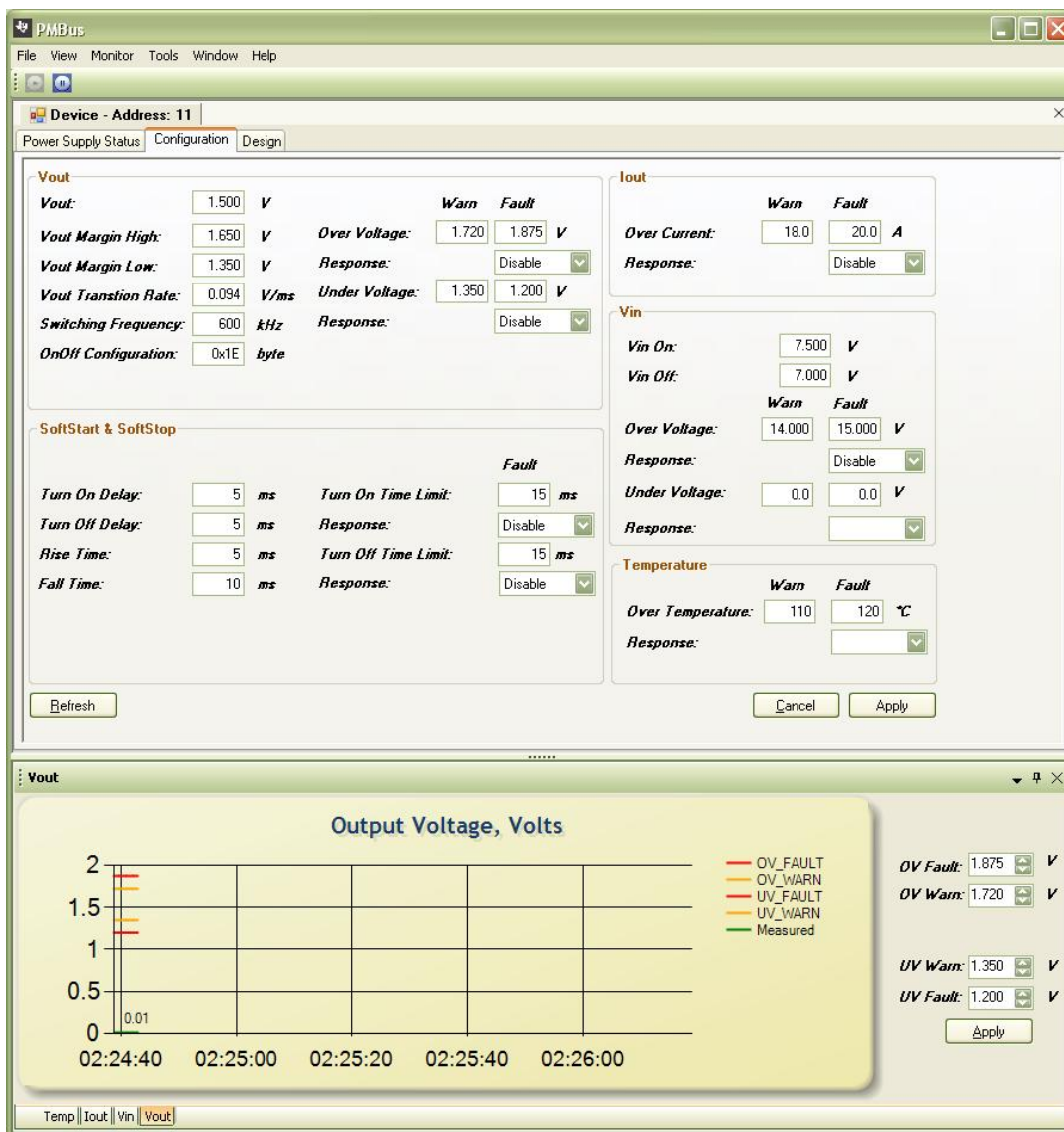

Figure 8-1. Example GUI Interface for POL Configuration

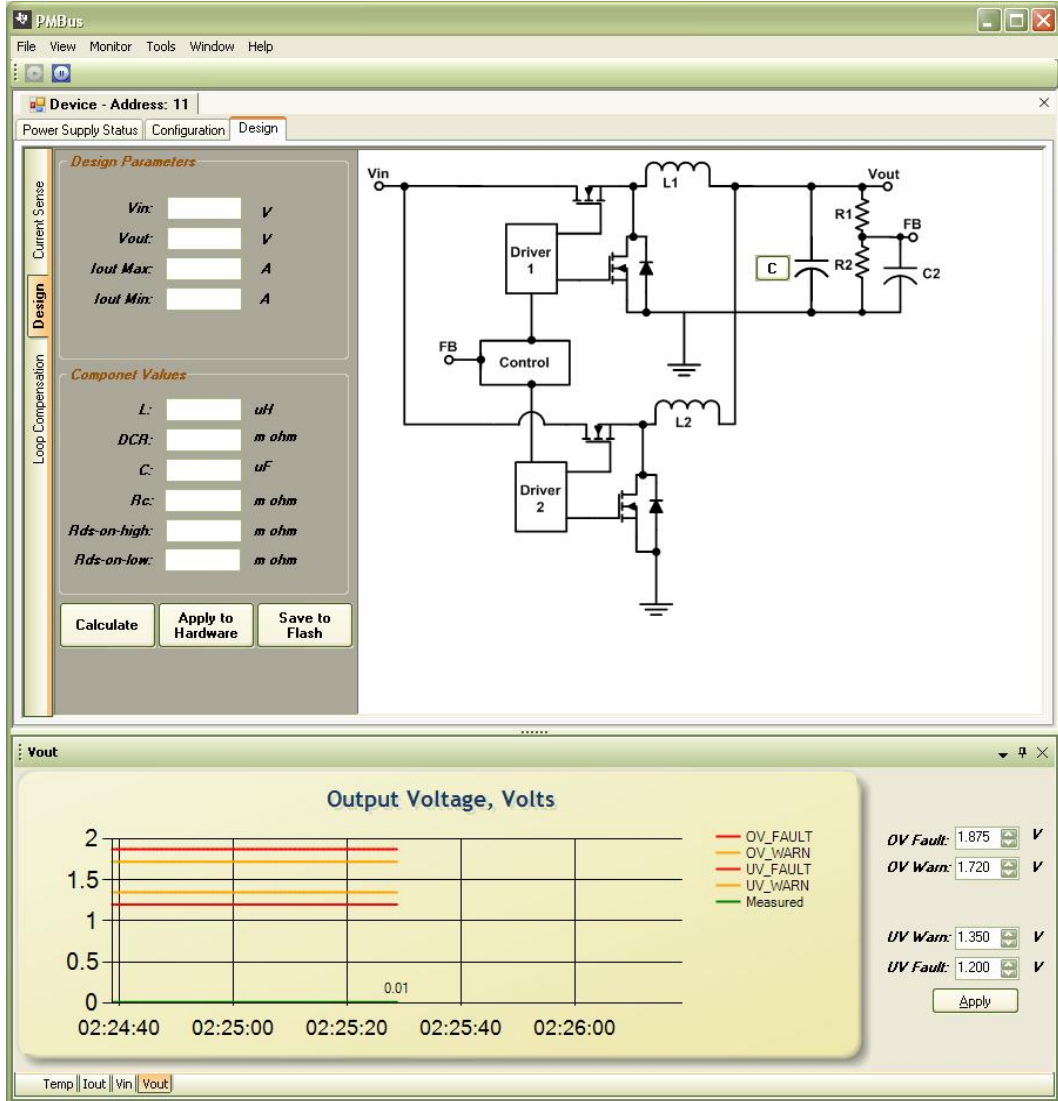
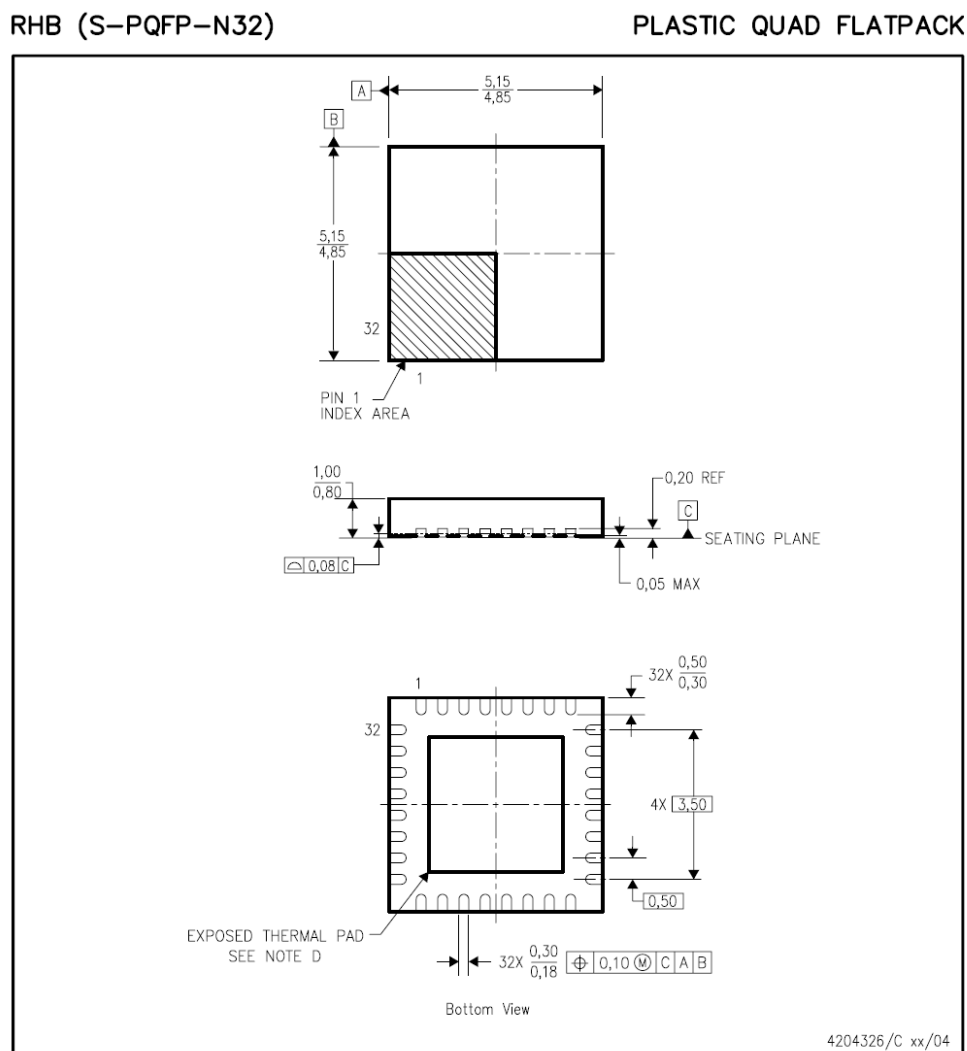

Figure 8-2. Example GUI Design Tool

9 PACKAGE INFORMATION

The UCD9111 is available in Texas Instruments' 32-pin PowerPAD™ plastic quad flatpack package.

Figure 9-1. 32-Pin PowerPAD™ QFN Package



- NOTES:
- All linear dimensions are in millimeters.
 - This drawing is subject to change without notice.
 - QFN (Quad Flatpack No-Lead) Package configuration.
 - The Package thermal pad must be soldered to the board for thermal and mechanical performance. See product data sheet for details regarding the exposed thermal pad dimensions.
 - Falls within JEDEC MO-220.